

SILAS LOUNGE CHAIR

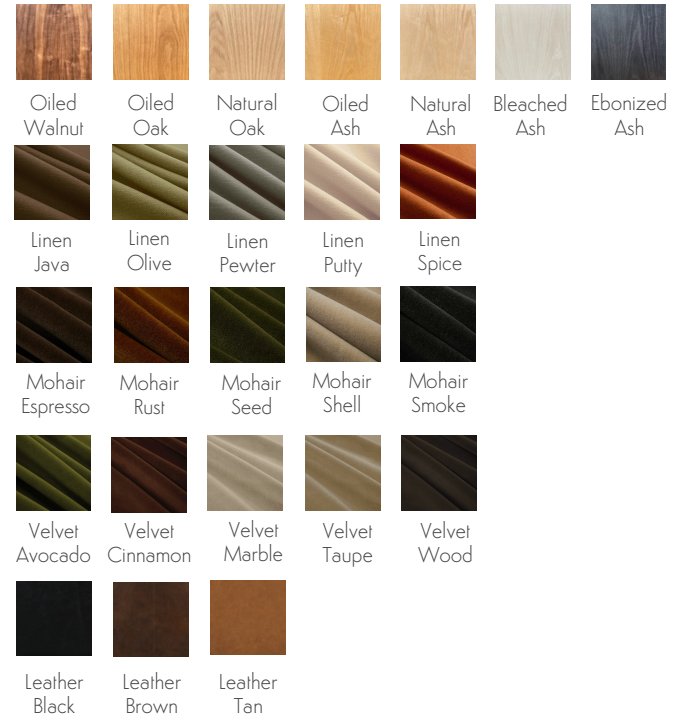

AVAILABLE FINISHES:



The Silas Lounge Chair uses an exposed solid wood frame to become the focal point for classic geometry, while maintaining a timeless feel. The silhouette of the soft bolster cushions cradled between the frame gives harmony in the contrasts of the materials.

The elegant leather sling provides an additional structural expression, allowing the chair to be appreciated from every point of view.

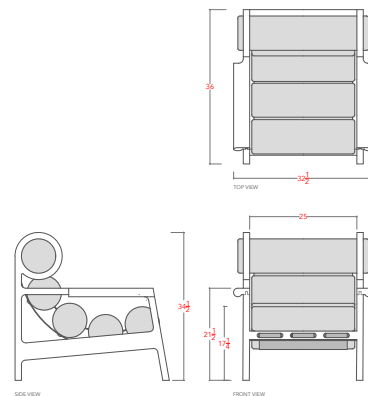

STARTING AT:

\$6,195

SHOWN IN: Natural Oak & Seed

LEAD TIME: 10-12 Weeks

STANDARD DIMENSIONS:

32.5" L x 36" D x 34.5" H

WEIGHT: 45 lbs

COM/COL: 4 Yards

PRODUCTION: Made to Order

MADE IN: Los Angeles

MATERIALS: FSC certified Ash, Oak, Walnut

CUSTOMIZATION: COM/ COL Options Available. Contact for more info.



LAST DITCH DESIGN